



Assembled tables are large & heavy. Put together at place of use.

Evo Pedestal Table Top Attachment

360936B Dining Base 360997B Bar Height Base

Thank you for selecting Tropitone furniture.

- ✓ Read through all steps before starting assembly.
- ✓ Locate all items in the Parts List from your cartons.

WARNING! Do not try to lift or flip furniture components with only one person. Components may be heavy and awkward to handle, and may result in injury to persons or damage to property if not lifted properly.

WARNING! Do not sit on or put your full weight on the edge of the table. Serious injury could result.

CAUTION: Proper screw length should allow 1/2" – 3/4" of threads to penetrate into the Top surface. Confirm proper screw length before starting Top attachment. See Step 1.

Tools Required

5/16" Socket Driver or Flathead Screwdriver
1/4" Hex Key (Allen Wrench)

Tape Measure
Permanent Marker (Felt Tip)
Safety Glasses

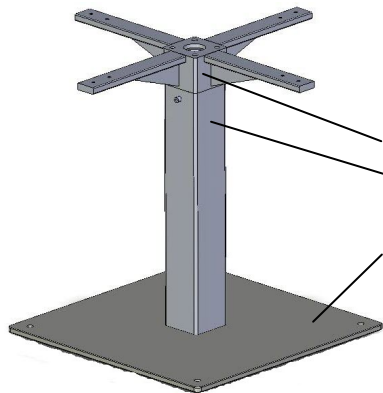

Parts List

- (1) Spider Support
- (1) Column: Dining Height or Bar Height
- (1) Base Plate
- (1) Thumbscrew
- (8) 5/16" x 1-1/4" Socket Head Cap Screws
- (8) #10 x 1-1/4" Self-Tapping Screws

Step 1

CAUTION: It is the assembler's and user's responsibility to confirm and install proper length screws to prevent damage to the Top.

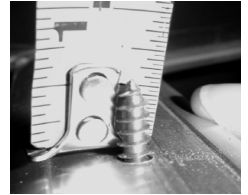

Place one screw into the Spider Support mount. Measure the length of the screw threads to insure they stick up 1/2" – 3/4".

- x** *If the screw sticks up more than 3/4", do NOT proceed. The screws are too long and will stick up through the Top surface.*
- x** *If the screw sticks up less than 1/2", do NOT proceed. The screws are too short and will not properly secure the Top.*

SCREW LOCATIONS (8 PLACES)

Step 2

Prepare a smooth, non-scratch work surface (shipping container, a tarp or pool towels can be used).

With two persons, place the Table Top upside down on the prepared work surface. Turn the Spider Support upside down and place onto the center of the Top.

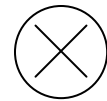
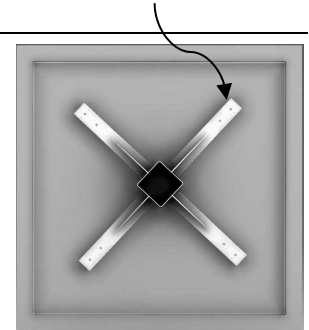

Square tops Be sure that the Spider Support arms point toward the corners of the top.

- **Top with umbrella hole** Sight down through the umbrella support ring and align to the hole on the Top.
- **Top without umbrella hole** Measure equal distances from the edge at four (4) places to center the Spider Support on the Top.

Using the permanent marker, make a small, discrete mark on the Base and the Top at two or more mounting points to indicate the alignment.

Lift the Spider Support off the Top. **Do NOT attach the Spider Support to the Top until Step 4.**

Step 3

Identify the top of the Column by locating the hole for the umbrella thumb screw; orient this up towards the Spider Support.

With two persons, hold the Column vertical and place the Spider Support onto the Column.

Install (4) Socket Head Cap Screws in the Spider Support into the counterbore holes. Fully tighten the screws with the 1/4" Hex Key.

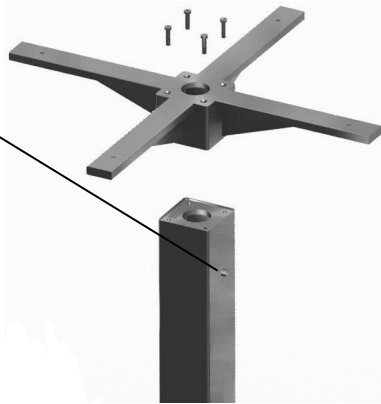

Step 4

Turn the Column assembly upside down onto the table Top; align the Spider Support to the marks made in Step 2. Attach the Base to the Top using eight (8) #10 self tapping screws.

NOTE: After assembling one table top, proceed to Step 5 to complete Table assembly and then turn upright. Confirm the screws have not penetrated up through the top surface.

Step 5

Position the Base Plate with the Glides up. With two persons, lift and hold the Base Plate onto the Column and align to the threaded holes. Install (4) Socket Head Cap Screws into the counterbore holes. Fully tighten the screws with the 1/4" Hex Key.

With two persons, lift up by the Base and Column to turn the table sideways then place the Base on the ground **without lifting by the Top**. Finish by lifting the Spider Support to tilt the table upright.

Install the umbrella (optional).

Install the umbrella Thumbscrew into the Column; fully tighten.

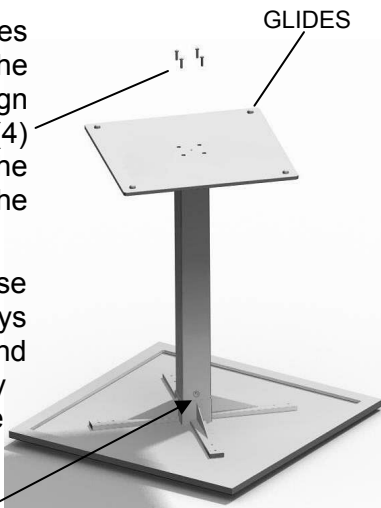

Tropitone®



MORE INFORMATION

For care and cleaning instructions, refer to the Tropitone Care, Maintenance, Safety & Warranty Information guide included with your furniture and available at www.tropitone.com – click on Product Care.

Additional care information, “How To” videos and assembly instructions for Tropitone Outdoor Furniture and Basta Sole shade products are also available at our website including:

- ✓ Evo Woven Modular Furniture Assembly
- ✓ Stoneworks Tops Touch Up
- ✓ Frame Finish Touch Up

If you have difficulty understanding any of the instructions and need assistance, please call Tropitone’s Customer Service Center at 949-951-2010.

Tropitone Furniture Co., Inc.
5 Marconi, Irvine, CA 92618

949 951 2010 phone
www.tropitone.com

Part # R9T00018
Revised: 02-08-10
©2010 Tropitone Furniture Co., Inc.